



Simply EASY!

PRESSURE SENSITIVE LABEL APPLICATOR

**SynerG XP series**

**XP100T - PAIL**



The SynerG XP100T Pail Labeler is a high-end labeling system providing maintenance-free operation for tapered and straight-sided pails. The machine applies single labels on pails ranging in size from 1/2 gallon to 6 gallons. Labels are held with wipe gates (saloon doors) during the labeling process. Extremely easy to use, the labeler provides both reliability and accuracy. Setup recipes are given names and recalled from the operator touch screen. Variables such as speeds, label and container lengths are automatically adjusted without moving sensors.

### CONSTRUCTION

- **Servo**-motor on labeling head(s)
- No proprietary electronics or microprocessors – components available worldwide
- **Servo**-motors on all motorized assemblies
- Robust stainless steel & high grade anodized aluminum construction
- Precision gradient scales on all adjustments: displayed in setup recipes
- User friendly color-evident anodized adjustments
- Tool-less changeovers
- Conveyor with side guides: 12" wide x 96" long x 38" high. Height adjustability of +/- 1"
- Top hold down module, digitally synchronized to conveyor
- Wipe gates



### CONTROL

- Programmable **servo**-controller (open architecture internal network)
- Standard 5.7" touch screen interface on electrical box
- On-screen diagnostics and speed controls
- Automatic missing label compensation/label length detection
- True scalable setting memorization for 50 set-up recipes
- Complete encoded synchronization
- Production quantity counter alert
- Digitally controlled gap and product sensors – never physically move the sensors again

### PERFORMANCE

- Single belt drive technology for fast and accurate ramp up and ramp down
- Synchronized speeds up to 1570"/min (40 meters/min)
- Precision label dispensing of +/- 1/16"
- Label position on product using the touch screen (extreme precision)
- Label held by angle-adjustable wipe gates



NITA - LABELING EQUIPMENT [WWW.NITALABELINGEQUIPMENT.COM](http://WWW.NITALABELINGEQUIPMENT.COM)  
1051 DU VIGER STREET, TERREBONNE (QC), CANADA, J6W 6B6, 1.877.961.4008



## SynerG XP Series XP100T Pail Labeler - Specifications

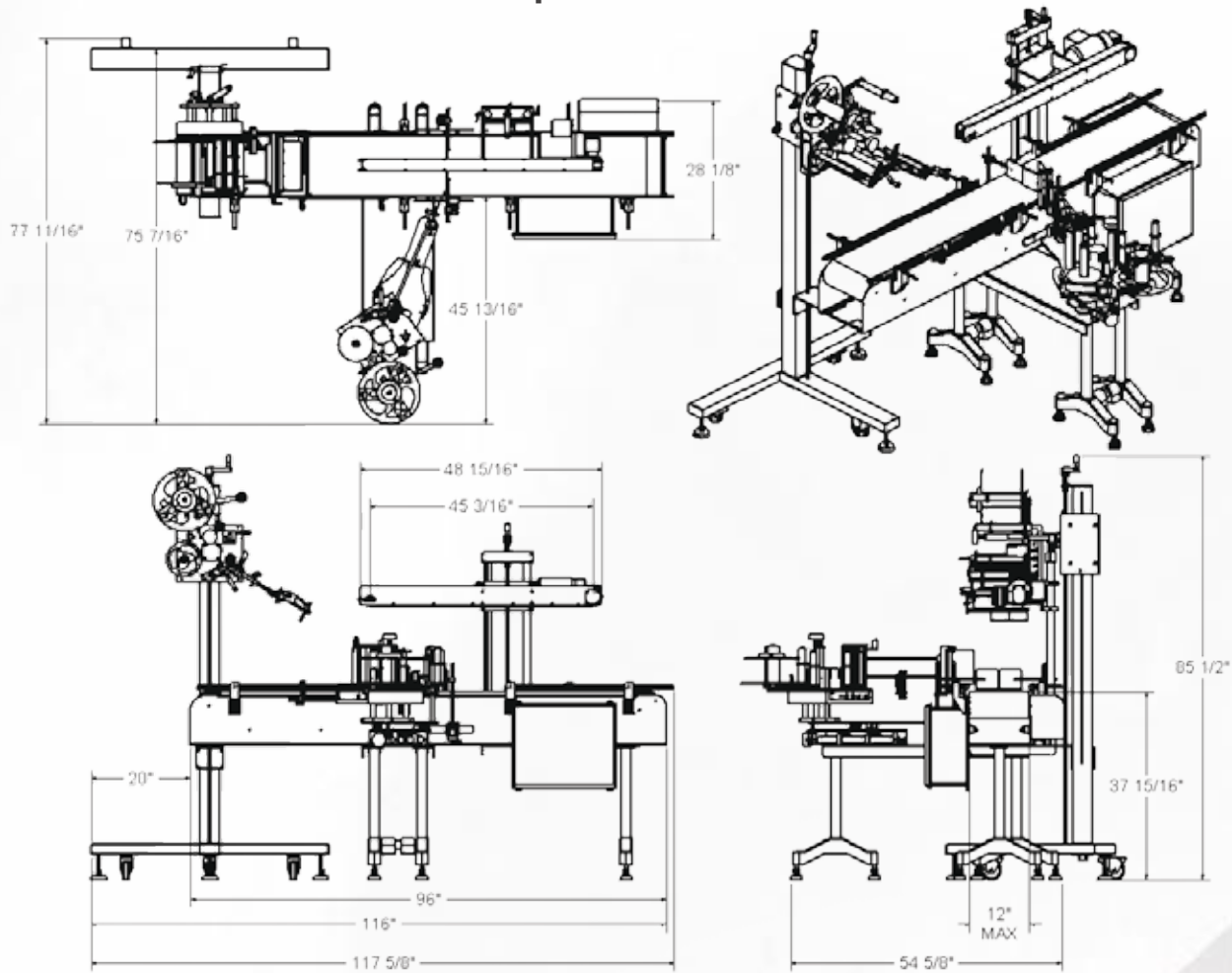

Power:	200-240 VAC, single phase, 60 Hz, 10 amps
Labeling rate:	Synchronized 1570"/min (40 meters/min)
Accuracy:	+/- 1/16"
Min. label:	1/2" wide x 1/2" long
Max. label:	6" wide x 25" long
Media roll size:	12" (305mm) OD on 3" (76mm) CORE
Motor:	(Encoded) synchronized SERVO
Controller:	Touch screen HMI
Weight:	350 Lbs.
Label detection:	Photoeye (fixed)
Available options:	<ul style="list-style-type: none"> <li>Spacing wheel</li> <li>Wide web width up to 9" (229mm)</li> <li>Clear label sensor</li> <li>Status lamp tower with audible alarm</li> <li>Cylinder or spider closing module</li> <li>Pneumatic/vacuum wipe gates</li> <li>Extra labeling head for top application</li> </ul>



Distributed by:

