

Automatic Print/Apply Label Applicator



 **auto labe**

MODEL 155

Toll Free 800-634-5376

MODEL 155

Auto Labe's new Print/Apply System integrates either a Tamp, Blow, Air-Tamp or Smart Tamp Label Applicator with High Performance Thermal Transfer and Direct Thermal Printers. The Model 155 incorporates an Allen Bradley PLC for easy menu driven operation and control. No more relays or circuit board problems to worry about. Built to last with only the best components available for maximum versatility and performance.

Features

- Exceptional placement accuracy.
- Built for industrial environment.
- Flexible mounting allows labeling from the side, top, or the bottom.
- Tamp-Down for recessed label application.

Specifications

Interface:

USB, RS232, Parallel and Twinax/Coax

Air Requirements:

3 CFM @ 90 PSIG

Electric Requirements:

110 VAC 60Hz/5 AMP
220 VAC 50 Hz

Equipment Weight:

Applicator & Print Engine Only
75 lbs/36kg (approximate)

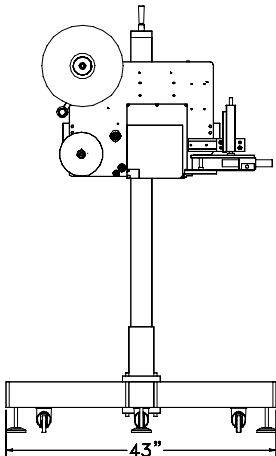
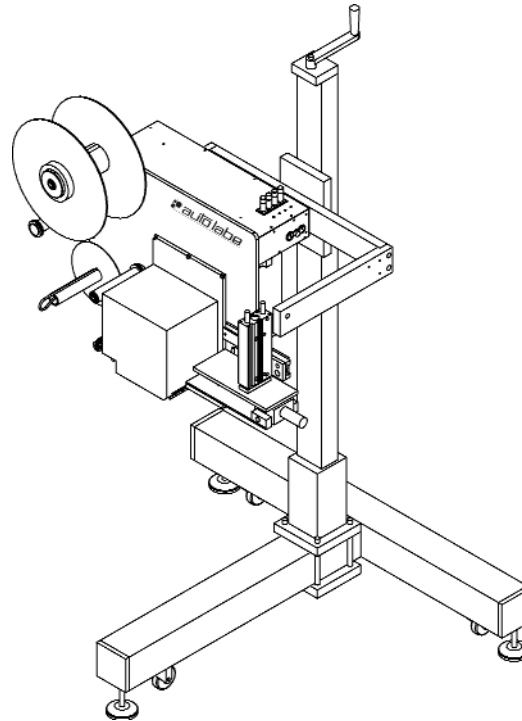

FRONT VIEW

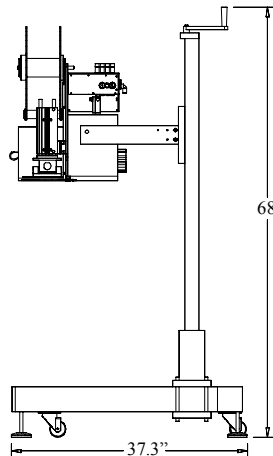

SIDE VIEW

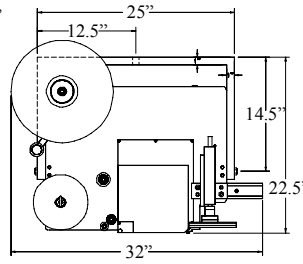

FRONT VIEW

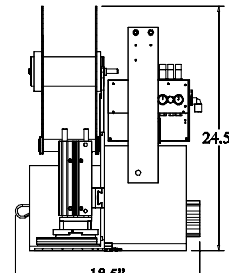

SIDE VIEW

PRINT ENGINE OPTIONS

SATO 8460Se

203dpi (8 dots/mm)
Print Speed: (Up to 8"/sec)
Maximum Print Area:
(6" Wide by 49.2" Long)
Printing Method: Thermal Transfer
Direct Thermal

SATO 8485Se

203dpi (8 dots/mm)
Print Speed: (Up to 12"/sec)
Maximum Print Area:
(5" Wide by 49.2" Long)
Printing Method: Thermal Transfer
Direct Thermal

SATO 8490Se

305dpi (12 dots/mm)
Print Speed: (Up to 8"/sec)
Maximum Print Area:
(4.4" Wide by 32.8" Long)
Printing Method: Thermal Transfer
Direct Thermal

ZEBRA 110PAX3

203 or 300 dpi
Print Speed: (12"/sec @ 203dpi)
Print Speed: (8"/sec @ 300dpi)
Maximum Print Area:
(4.1" Wide by 39" Long)
Printing Method: Thermal Transfer
Direct Thermal

ZEBRA 170PAX3

203 or 300 dpi
Print Speed: (12"/sec @ 203dpi)
Print Speed: (8"/sec @ 300dpi)
Maximum Print Area:
(6.6" Wide by 39" Long)
Printing Method: Thermal Transfer
Direct Thermal

DATAMAX A-4212

203dpi (8 dots/mm)
Print Speed: (2" to 12"/sec)
Maximum Print Area:
(4.094" Wide by 99" Long)
Printing Method: Thermal Transfer
Direct Thermal

DATAMAX A-4308

300dpi (12 dots/mm)
Print Speed: (2" to 8"/sec)
Maximum Print Area:
(4.16" Wide by 99" Long)
Printing Method: Thermal Transfer
Direct Thermal

DATAMAX A-6210

203dpi (8 dots/mm)
Print Speed: (2" to 10"/sec)
Maximum Print Area:
(6.61" Wide by 99" Long)
Printing Method: Thermal Transfer
Direct Thermal

Options/Accessories

- Tamp/Blow Labeling
- Adjacent Side Carton Labeling
- Corner Wrap Carton Labeling
- Smart Tamp Labeling
- Web Monitoring System
- Accumulators/Descramblers
- Heavy Duty T-Base Stand
- Custom Hardware and Mounts
- Custom Conveyors
- Spare Parts Kits
- Software Packages
- Print Pad
- Computers
- Ribbon Stock
- Label Stock

Over 35 years of commitment to quality and innovation in the Pressure Sensitive Labeling Industry



DIVISION OF BOOTH MANUFACTURING COMPANY

3101 Industrial Avenue Two, Fort Pierce, Florida 34946

Toll Free 800-634-5376 • 772-465-4441 • FAX 772-465-5177



DISTRIBUTED BY: